

[Baratè]

ALLUMINIO

[TOLLERANZE EN]

Barre piatte estruse

Gruppo 1	Gruppo 2
EN AW-1050A	EN AW-2007
EN AW-6026	EN AW-2011
EN AW-6060	EN AW-7075
EN AW-6063	
EN AW-6082	



Tabella 1 – Gruppo Leghe 1

Larghezza "b"		Spessore "a"							
Dimensioni	Toll.	> 2	> 6	> 10	> 18	> 30	> 50	> 80	> 120
		≤ 6	≤ 10	≤ 18	≤ 30	≤ 50	≤ 80	≤ 120	≤ 150
10 ≤ 18	±0,25	±0,20	±0,25	±0,25	-	-	-	-	-
18 ≤ 30	±0,30	±0,20	±0,25	±0,30	±0,30	-	-	-	-
30 ≤ 50	±0,40	±0,20	±0,25	±0,30	±0,35	±0,40	-	-	-
50 ≤ 80	±0,60	±0,25	±0,30	±0,35	±0,40	±0,50	±0,60	-	-
80 ≤ 120	±0,80	±0,30	±0,35	±0,40	±0,45	±0,60	±0,70	±0,80	-
120 ≤ 180	±1,0	±0,35	±0,40	±0,45	±0,50	±0,60	±0,70	±0,90	±1,0
180 ≤ 240	±1,4	-	±0,45	±0,45	±0,50	±0,70	±0,80	±1,0	±1,2
240 ≤ 300	±1,7	-	±0,45	±0,50	±0,60	±0,70	±0,80	±1,1	±1,3
300 ≤ 400	±2,0	-	-	±0,60	±0,70	±0,80	±0,90	±1,2	±1,4
400 ≤ 500	±2,5	-	-	-	-	±0,90	±1,0	±1,3	±1,7
500 ≤ 600	±3,0	-	-	-	-	±0,90	±1,0	±1,4	-

Tabella 2 – Gruppo Leghe 2

Larghezza "b"		Spessore "a"							
Dimensioni	Toll.	> 2	> 6	> 10	> 18	> 30	> 50	> 80	> 120
		≤ 6	≤ 10	≤ 18	≤ 30	≤ 50	≤ 80	≤ 120	≤ 150
10 ≤ 18	±0,35	±0,25	±0,30	±0,35	-	-	-	-	-
18 ≤ 30	±0,40	±0,25	±0,30	±0,40	±0,40	-	-	-	-
30 ≤ 50	±0,50	±0,25	±0,30	±0,40	±0,50	±0,50	-	-	-
50 ≤ 80	±0,70	±0,30	±0,35	±0,45	±0,60	±0,70	±0,70	-	-
80 ≤ 120	±1,0	±0,35	±0,40	±0,50	±0,60	±0,70	±0,80	±1,0	-
120 ≤ 180	±1,3	±0,40	±0,45	±0,55	±0,70	±0,80	±1,0	±1,1	±1,3
180 ≤ 240	±1,6	-	±0,50	±0,60	±0,70	±0,90	±1,1	±1,3	±1,5
240 ≤ 300	±2,0	-	±0,50	±0,65	±0,80	±0,90	±1,2	±1,4	±1,6
300 ≤ 400	±2,5	-	-	±0,70	±0,90	±1,0	±1,2	±1,6	±1,8
400 ≤ 500	±3,0	-	-	-	-	±1,1	±1,3	±1,8	±2,0
500 ≤ 600	±3,5	-	-	-	-	±1,2	±1,4	±1,8	-

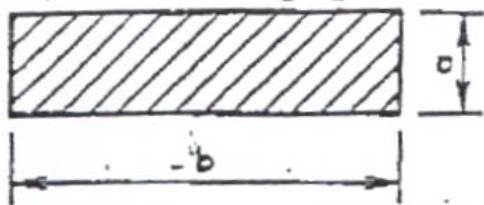
Tabella 3 – Planarità

Larghezza "b"		Toll. Ammessa "a"
>	<	
-	30	0,2
30	50	0,3
50	80	0,4
80	120	0,6
120	180	0,9
180	240	1,2
240	350	1,5
350	450	2,0
450	600	2,5



Tabella 4 – Rettilinearità

Larghezza "b"		Spessore "a"	Rettilinearità Ogni metro Per 300 mm	
>	<		h1	h2
-	80	$\geq 2 \leq 80$	1	0,7
80	120	$\geq 2 \leq 50$	1	0,5
		$\geq 50 \leq 120$	1	0,5
120	180	$\geq 2 \leq 50$	1	0,5
		$\geq 50 \leq 150$	1	0,5
180	350	$\geq 6 \leq 50$	1	0,5
		$\geq 50 \leq 150$	1	0,5
350	450	2,0	1	0,5

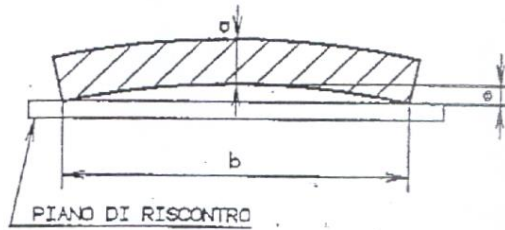

Tabella 5 – Svergolatura

Larghezza "b"		Svergolatura "v"		
>	≤	Per metro	Lunghezza totale	
			≤ 5000	> 5000
-	30	1,5	3	Da concordare
30	50	2	5	
50	120	3	7	
120	240	4	10	
240	350	5	12	
350	600	6	14	

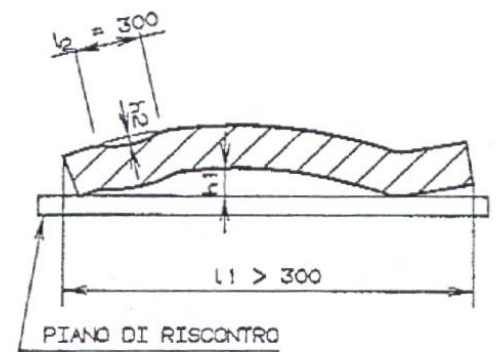
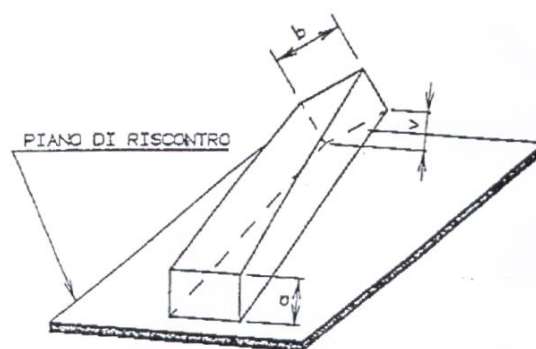

Tabella 5 – Tolleranza raggi

Lato "a"		Raggi per gruppo	
>	<	I max.	II max.
-	30	1.0	2.0
30	50	1.5	3.0
50	120	2.0	4.0
120	200	3.0	6.0